

ACCOUNTS OF CHEMICAL RESEARCH

VOLUME 7

NUMBER 4

APRIL, 1974

Tetramethyl-1,2-dioxetane. Experiments in Chemiexcitation, Chemiluminescence, Photochemistry, Chemical Dynamics, and Spectroscopy

Nicholas J. Turro,* Peter Lechtken, Neil E. Schore, Gary Schuster, Hans-Christian Steinmetzer, and Ahmad Yekta

Chemistry Department, Columbia University, New York, New York 10027

Received October 22, 1973

An effective way of generating student interest in chemical processes is the simple, visual demonstration of unusual chemical phenomena.¹ A splendid example is a chemiluminescence reaction. The observation of "cold liquid light" streaming out of a flask is a delight to behold and a fascinating challenge to understand. In nature, many charming examples of chemiluminescence have been noted in the bioluminescence² of the firefly and in luminous bacteria, fungi, deep sea fish, and other species.

Chemiluminescence occurs when a sizable fraction of the exothermicity (ΔH) of a chemical reaction is converted into electronic excitation energy ($*$) of a reaction product,³ which then emits a photon of light ($h\nu$). We can describe chemiluminescence as a $\Delta H \rightarrow * \rightarrow h\nu$ sequence. The heart of the latter is the *chemiexcitation* ($\Delta H \rightarrow *$) step. The $* \rightarrow h\nu$ process is an ordinary and well-understood luminescence step which serves to announce the presence of an electronically excited state. If we consider photochemistry as a $h\nu \rightarrow * \rightarrow \Delta H$ sequence, we can imagine that a conceptual link exists between chemiluminescence

phenomena (photochemistry in reverse!) and photochemical reactions.

Since chemiluminescence can be divided into a *chemiexcitation* and a *luminescence* stage, we have two experimental chores: (a) identification of the key chemiexcitation step and (b) identification of the luminescent species. It is desirable, therefore, to set as a goal the development of a chemiluminescent system which requires only these two steps.

In this Account we show that the 1,2-dioxetane ring system admirably approaches the ideal requirements of a chemiluminescent system. Study of the mechanism of the $\Delta H \rightarrow *$ step in the thermolysis of the 1,2-dioxetanes allows a blending of the ideas of classical kinetics and molecular spectroscopy. Also, it provides insight concerning the mechanism and concepts of nonadiabatic reactions, spin-flipping processes, cycloelimination reactions, and intramolecular energy exchanges which are all interwoven in the $\Delta H \rightarrow *$ step in the 1,2-dioxetane decompositions.

Moreover, we show how appropriate coupling of the high selectivity and efficiency of the *chemiexcitation* step (eq 1) with the experimental simplicity and sensitivity of the *luminescence* step (eq 2) allows us to utilize the chemiluminescence of 1,2-dioxetanes: (a) to discover new processes such as quantum chain reactions, anti-Stokes sensitization processes, and excitation energy hopping from one solvent molecule to another solvent molecule; (b) to develop new concepts for photochemistry, such as a "masked" excited state; and (c) to study in detail mechanisms of electronic energy transfer, diffusion of mass and dif-

Nicholas Turro received a B.A. degree from Wesleyan University in 1960, took his Ph.D. from Caltech, did a year's postdoctoral work at Harvard, and then joined the faculty at Columbia, where he is now Professor of Chemistry. He has research interests in many areas, including work on cyclopropanes and on molecular photochemistry of alkanones in solution, which have been the subjects of previous Accounts. He is recipient of the 1974 ACS Award in Pure Chemistry sponsored by Alpha Chi Sigma Fraternity and of the 1973 Fresenius Award in Chemistry sponsored by the Psi Lambda Upsilon Fraternity.

Peter Lechtken was awarded the Ph.D. by Universität Erlangen and returned there to join the faculty on completion of a NATO Postdoctoral Fellowship at Columbia in 1972-1973. Neil Schore, who is a postdoctoral fellow at Caltech, received his Ph.D. at Columbia working with Dr. Turro. Gary Schuster's Ph.D. work was done at the University of Rochester. Following a hitch in the Army, Dr. Schuster is doing postdoctoral research at Columbia. Hans-Christian Steinmetzer received the Ph.D. from Universität Würzburg, did postdoctoral work at Columbia, and is now at Universität Frankfurt. Ahmad Yekta, who is now on the faculty of Ayr-Mehr University in Tehran, obtained the Ph.D. at Columbia in 1973.

(1) Review of chemiluminescence: F. McCapra, *Progr. Org. Chem.*, **8**, 231 (1971); examples of chemiluminescence demonstrations: E. H. White, *J. Chem. Educ.*, **34**, 275 (1957).

(2) Review of bioluminescence: J. W. Hastings, *Annu. Rev. Biochem.*, **37**, 597 (1968).

(3) Review of chemiexcitation mechanisms: R. F. Vasilev, *Russ. Chem. Rev.*, **39**, 529 (1970).

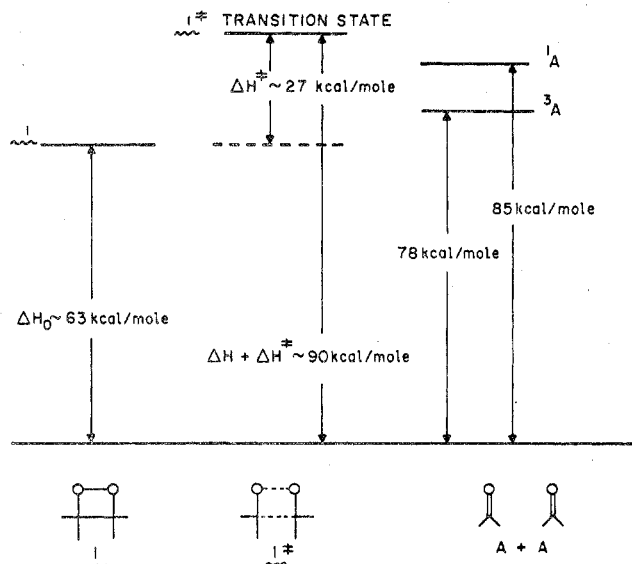
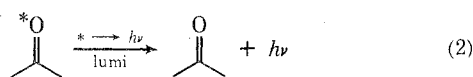
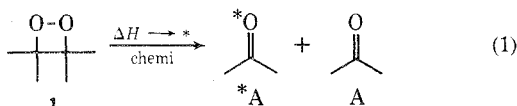

Figure 1. Energetics of the tetramethyl-1,2-dioxetane and acetone systems. The energy of two ground-state acetones is considered as the zero point for comparison.

fusion of excitation in fluid solvents, and cage effects.



The Involvement of 1,2-Dioxetanes in Chemiluminescent Reactions

Many efficient chemiluminescent reactions appear to involve oxygen in some form, *i.e.*, O₂, a peroxide, or its equivalent.⁴ All 1,2-dioxetanes prepared to date are either chemiluminescent or capable of inducing the luminescence of an additive.⁵ White,⁶ in a brilliant series of papers, demonstrated how "photochemistry in the dark" could be employed for the useful generation of electronically excited molecules by thermal reactions. The $\Delta H \rightarrow *$ step appears to be common to the thermolysis of 1,2-dioxetanes, all of which cleanly dissociate into two carbonyl fragments.⁶⁻⁸ What are the structural features and mechanistic details of 1,2-dioxetane thermolysis? What makes this ring system such a common ingredient in chemiluminescent systems? In other words, what qualities of 1,2-dioxetane thermolysis enable the $\Delta H \rightarrow *$ to occur?

There are two general requirements for an efficient chemiluminescence system: (a) the conversion of the transition state to a chemiexcited species must be exothermic and (b) there must be a mechanism available to convert most of the energy of the transi-

tion state into electronic excitation energy of a product molecule.^{9,10} Importantly, the mechanism of the latter process is related to that of the essential step in most photoreactions, which involves a change in electronic state as electronically excited molecule converts to a ground-state product.¹¹

As can be seen from Figure 1, the sum of ΔH_0 and ΔH^\ddagger (≈ 90 kcal/mol)¹² for tetramethyl-1,2-dioxetane (1) is greater than that required to excite an acetone singlet, ¹A, or acetone triplet, ³A (85 and 78 kcal/mol, respectively). Thus, both ¹A and ³A are energetically accessible^{13,14} from the transition state for thermolysis of 1. Experimentally, how does one demonstrate quantitatively the extent of the chemiexcitation step and what are the mechanistic details of the process?

Experimental Demonstration of Chemiexcited Acetone from Tetramethyl-1,2-dioxetane

The hero of this Account is tetramethyl-1,2-dioxetane (1). This remarkable molecule possesses an exceptionally high energy content^{12,13} (Figure 1) as a result of its peculiar electronic structure which combines the strain energy of a small ring, the weakness of an O-O bond linkage, and the potential for a huge energy release with the simultaneous formation of the two carbonyl groups. It is astounding that 1 is kinetically stable¹⁵ at room temperature ($t_{1/2} \approx$ several days at 20°)!

Kopecky's method¹⁶ of base treatment of α -bromo hydroperoxides is the present method of choice for preparation of 1. Remarkably, 1 can be recrystallized

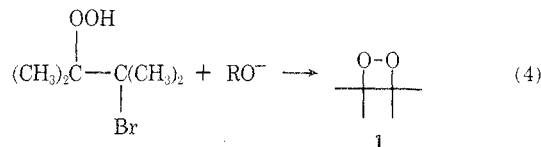
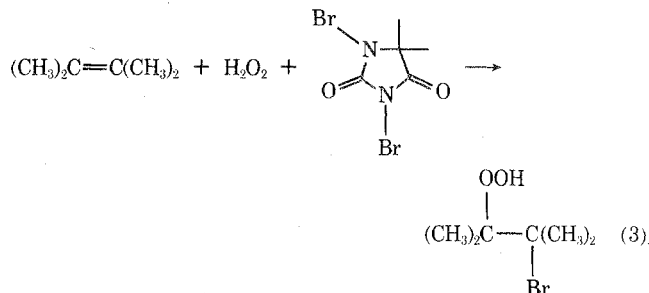

from pentane to yield beautiful yellow needles (mp 78–80° dec). Solid 1 has a sharp, acrid odor and may be repeatedly sublimed at room temperature without noticeable change. At room temperature, it glows

(9) T. Forster, *Pure Appl. Chem.*, **24**, 443 (1970).

(10) R. G. Gilbert and I. G. Ross, *Aust. J. Chem.*, **24**, 1541 (1971).

(11) G. S. Hammond, *Advan. Photochem.*, **7**, 373 (1969); J. Jortner, *Pure Appl. Chem.*, **27**, 389 (1971).

(12) Measurement of ΔH_0 : P. Lechtken and G. Hohne, *Agnew. Chem., Int. Ed. Engl.*, **12**, 772 (1972). Measurement of ΔH^\ddagger : N. J. Turro and P. Lechtken, *J. Amer. Chem. Soc.*, **95**, 264 (1973).

(13) W. H. Richardson and H. E. O'Neil, *J. Amer. Chem. Soc.*, **94**, 8665 (1972).

(14) The 0,0 bands of acetone phosphorescence and fluorescence are not well defined. As a result, the singlet and triplet energies of acetone are probably accurate to only a few kilocalories/mole: J. C. Dalton and N. J. Turro, *Annu. Rev. Phys. Chem.*, **21**, 499 (1970).

(15) Many of the 1,2-dioxetanes prepared to date are relatively stable at room temperature. In some cases, the kinetic stability is limited by a catalytic, nonchemiluminescent decomposition pathway: T. Wilson, M. Landis, A. L. Baumstark, and P. D. Bartlett, *J. Amer. Chem. Soc.*, **95**, 4765 (1973).

(16) K. R. Kopecky and C. Mumford, *Can. J. Chem.*, **47**, 709 (1969).

(4) T. Wilson and J. W. Hastings, *Photophysiology*, **5**, 49 (1970).

(5) T. Wilson in "Chemiluminescence and Bioluminescence," M. J. Cornier, D. M. Hercules, and J. Lee, Ed., Plenum Press, New York, N. Y., 1973.

(6) E. H. White, P. D. Wildes, J. Wiecko, H. Doshan, and C. C. Wei, *J. Amer. Chem. Soc.*, **95**, 7050 (1973); P. D. Wildes and E. H. White, *ibid.*, **93**, 6286 (1971); E. H. White, J. Wiecko, and D. F. Roswell, *ibid.*, **91**, 5194 (1969); E. H. White and J. Wiecko, and C. C. Wei, *ibid.*, **92**, 2167 (1970).

(7) W. Adam and H. C. Steinmetzer, *Angew. Chem., Int. Ed. Engl.*, **11**, 540 (1972).

(8) T. Wilson and P. Schaap, *J. Amer. Chem. Soc.*, **93**, 4126 (1971).

spontaneously. 1 is soluble in most organic solvents and moderately soluble in water.

This dioxetane does have its limitations, of course, and occasionally, when heated or struck sharply with a hammer, it explodes. Although there has been no evidence of any hazardous behavior of 1 in solution, 1 must be treated, as with all peroxides, as a potentially explosive material.

The fascinating ability of 1 to "store" a large quantity of electronic excitation energy must have an interesting mechanistic origin. First, however, let us consider the details of the thermolysis of 1 and the evidence for generation of 3A .

Thermolysis of 1 in solution under a variety of conditions yields 2 mol of acetone (eq 5)

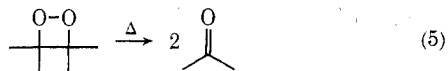

The primary yield of 1A and 3A from thermolysis of 1 was first measured by *chemical titration*¹⁷ of acetone excited states with *trans*-dicyanoethylene (*t*-DCE). The latter reagent reacts with 1A to yield only oxetane 2 and with 3A to yield only *cis*-dicyanoethylene (*c*-DCE) and a ground-state acetone molecule.¹⁸ Thermolysis of 1 in the presence of *t*-

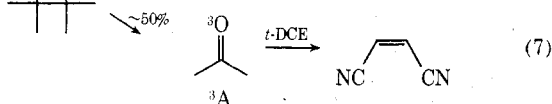
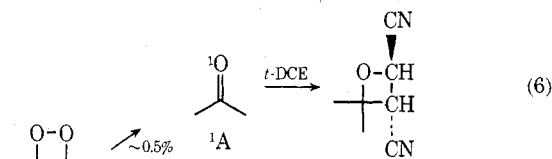

DCE, and extrapolation of the yield of 2 and of *c*-DCE to infinite concentration of *t*-DCE, allow us to determine the primary yield of 1A , *i.e.*, $^*\phi^S$ and the primary yield of 3A , *i.e.*, $^*\phi^T$.

This unexpected experimental result¹⁷ forced the conclusion that $^*\phi^S \approx 0.5\%$ and $^*\phi^T \approx 50\%$! Thus, the predominant primary path in decomposition of 1 is the selective and efficient generation of 3A . Thus an electronically nonadiabatic, spin-forbidden pericyclic fragmentation has occurred.

A simple, striking, and convincing experimental verification of this conclusion was possible. The chemiluminescence of 1 consists of both acetone fluorescence (eq 8) and phosphorescence (eq 9).¹⁹ The



latter is very sensitive to quenching by O_2 , whereas the former (because of the much shorter lifetime of the excited singlet) is not. Deaeration of a solution of 1 by simple nitrogen purging results in chemiluminescence which is essentially pure *acetone phosphorescence* (λ_{max}^P 430 nm).^{19,20} If air is admitted to

the initially deaerated solution, the chemiluminescence intensity immediately drops to about 0.01 of its original value and the chemiluminescence maximum shifts to 400 nm, the precise position of pure *acetone fluorescence*. In the absence of air, the chemiluminescence from 1 is essentially pure phosphorescence because $^*\phi^T \gg ^*\phi^S$ (eq 6 and 7), but in the presence of air $\phi_F \gg \phi_P$ due to oxygen quenching of 3A .

It is well known²¹ that selection rules for *photoexcitation* of A to 1A or 3A strongly prohibit formation of the triplet by a factor of about 1000. However, as we have seen above, the "selection rules" for chemiexcitation of 1 to 1A or 3A are completely reversed from the photoexcitation selection rule and the production of 3A relative to 1A is favored by more than a factor of 100. Our recent studies of other dioxetane systems suggest that the selection rule, $^*\phi^T \gg ^*\phi^S$, may be general for 1,2-dioxetanes.

We have thus exposed some remarkable facets of the molecular personality of 1. Not only does this species know how to persevere with large excesses of electronic energy but also, when forced to release its energy store, it prefers to do so by selectively and efficiently populating 3A . What is the mechanistic origin of this peculiar preselection for a spin flip ($1 \rightarrow ^3A$) when an energetically viable spin-preserving process ($1 \rightarrow ^1A$) is available, and why is chemiexcitation so efficient?

Mechanism of Chemiexcitation (the $\Delta H \rightarrow ^*$ Step)

A central question which can be asked of all photoreactions is: "At what point during the reaction does the electronic *deexcitation* or electronic relaxation occur?"^{11,22} This question is of importance because the rates of photoreactions and hence the efficiencies and yields of photoproducts might depend on the rate of electronic relaxation. The same kind of question can be asked about a reaction involving chemiexcitation: "At what point does electronic excitation occur?" In both cases we are fundamentally concerned with how electronic excitation energy is converted into nuclear motion and chemical energy and *vice versa*.

Let us delineate the structural features which might determine the rates of the $^* \rightarrow \Delta H$ and $\Delta H \rightarrow ^*$ steps in thermolysis of 1 from our experimental findings that 1 yields 3A in high efficiency, and that ΔE_a for decomposition of 1 and numerous other 1,2-dioxetanes is not much different from ΔE_a for breaking a "normal" O-O bond.²³

These observations suggest that stretching of the O-O bond is a dominant factor in forming the transition state for thermolysis of 1. Two families of possibilities for the mechanism of yielding chemiexcited products then come to mind: (a) a family originating from the notion that a biradical *intermediate*

(17) (a) N. J. Turro and P. Lechtken, *J. Amer. Chem. Soc.*, **94**, 2886 (1972); (b) N. J. Turro and P. Lechtken, *Pure Appl. Chem.*, **33**, 353 (1973). Earlier solvent effects on the reaction activation enthalpy are likely to be due to catalytic effects.¹⁵

(18) J. C. Dalton, P. A. Wriede, and N. J. Turro, *J. Amer. Chem. Soc.*, **92**, 1318 (1970).

(19) Acetone fluorescence: A. Halpern and W. R. Ware, *J. Chem. Phys.*, **54**, 1271 (1971). Acetone phosphorescence: N. J. Turro, H. C. Steinmetzer, and A. Yekta, *J. Amer. Chem. Soc.*, **95**, 6468 (1973).

(20) The inherent fluorescence rate constant of acetone is estimated to be approximately 10^6 sec^{-1} : M. O'Sullivan and A. C. Testa, *J. Phys. Chem.*, **77**, 1830 (1973). The inherent phosphorescence rate constant of acetone is estimated to be approximately 50 sec^{-1} : E. H. Gilmore, G. E. Gibson, and D. S. McClure, *J. Chem. Phys.*, **23**, 399 (1955). The ratio of these lifetimes reflects the singlet/triplet prohibition factor for acetone.

(21) N. J. Turro, "Molecular Photochemistry," W. A. Benjamin, New York, N. Y., 1967.

(22) L. Salem, W. G. Dauben, and N. J. Turro, *J. Chim. Phys.*, **70**, 694 (1973).

(23) S. W. Benson, "Thermochemical Kinetics," Wiley, New York, N. Y., 1968.

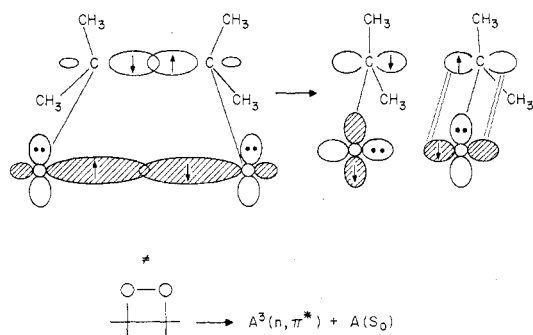
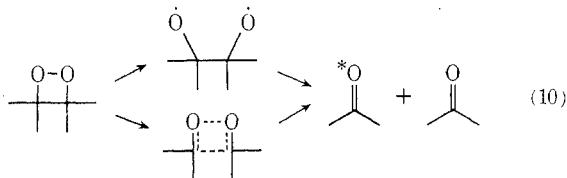

Figure 2. Schematic of a concerted, nonadiabatic, spin-forbidden thermolysis of **1**. The homolytic cleavage of the O-O bond is imagined to involve the effective rotation of electronic charge about one of the CO axes (arbitrarily shown as the oxygen atom on the left). This movement of electronic charge is analogous to a p_x to p_z orbital jump. This process (a) converts **1** into an n, π^* state of acetone and a ground state of acetone and (b) allows orbital and spin decoupling of the incipient n and π^* electrons.

is involved in which the O-O bond is *completely broken*; (b) another family of possibilities originating from the idea that, although the O-O bond is quite elongated as the transition state is approached, breaking of the C-C bond plays a significant role in the chemiexcitation pathway.



The biradical mechanism is consistent with available kinetic information and with thermochemical calculations.²⁴ The high value of $^*\phi^T$ may be rationalized, in terms of the biradical mechanism, by supposing that a singlet biradical is produced which may reclose to **1**, yield two ground-state singlet molecules, or undergo intersystem crossing to a triplet biradical. The latter may decompose only to triplet products.

In Figure 2 a possible transition state for concerted decomposition of **1** is shown in which the O-O bond is severely stretched and the C-C bond is significantly weakened. Now compare the electronic structure of this transition state (TS) with the electronic structure of the products, an acetone ground-state molecule and a n, π^* state. In going from TS $\rightarrow n, \pi^*$ state, electric charge must be moved from a region *above and below* the original molecular plane of the four membered ring into a region *in* the original molecular plane of the four-membered ring. This movement of charge can be described in terms of an electronic transition from a p_x orbital (perpendicular to the molecular plane) into a p_z orbital (in the molecular plane).²⁵ Furthermore, according to this picture the "business end" of the major electronic charge is localized on the left-hand oxygen atom.

If this mechanism were accurate, what might we expect with respect to its effect on the chemiexcitation step? From the concepts of molecular spectro-

scopy²⁵ a $p_x \rightarrow p_z$ electronic transition would result in an enormous facilitation of rate of spin flipping. The physical reason for this derives from the generation of a strong magnetic field as the electron jumps from one orbital into another orbital at right angles to the originally occupied one. This is an example of *electron spin-orbital coupling*: when spin and orbital momentum can be "coupled" or exchanged, spin selection rules break down and spin flips become allowed. This coupling of electron spin momentum with electron angular momentum is the key mechanism for the singlet \rightleftharpoons triplet process in organic molecules.

In order to appreciate the effect of spin-orbital coupling we need only consider the $n_O \rightarrow \pi_{CO}^*$ transition of ketones. Indeed, this process is electronically analogous to the $p_x(\sigma_0^*) \rightarrow p_z(\pi_0^*)$ transition shown in Figure 2. The inherent probability of absorption or emission from an n, π^* triplet is about 10^3 times greater than that from a π, π^* triplet. In the latter case no $p_x \rightarrow p_z$ transition is possible.

Furthermore, since the $p_x \rightarrow p_z$ transition is more or less localized on the oxygen atom,²⁵ energy is concentrated on the carbonyl group; this is also what happens when a carbonyl function undergoes a $n \rightarrow \pi^*$ excitation or $\pi^* \rightarrow n$ relaxation. From analysis of the n, π^* absorption and emission spectra of carbonyl compounds, it is concluded that electronic excitation is highly localized on the C=O function. Interestingly, the C-O bond length, the dipole moment, the shape of the ring carbon, and energy content of **1** are more similar to those of 1A than to 0A .

Strategy for Triggering and Utilizing Chemiexcitation

The strategy for use of **1** in studying reaction mechanisms is based on the ability to trigger the selective and efficient production of *A at will and under controlled conditions. Chemiexcitation allows a tremendous advantage over photoexcitation in the case of acetone because the latter only feebly absorbs uv light so that selective photoexcitation of acetone in the presence of any strongly absorbing species is technically nearly impossible. The $\Delta H \rightarrow ^*A$ path, however, allows specific excitation of *A in the presence of strongly absorbing materials or solvents.

Furthermore, since *both* 1A and 3A emit light and since modern techniques for detection of chemiluminescence are sensitive and precise, studies can be made under conditions such that the decrease in concentration of **1** is negligible during the time of measurement! This enormously simplifies the experimental procedures and kinetic analysis, since the steady-state assumption is readily applied to the reaction system. In the study of conventional photo-reactions, a steady continuous excitation of molecules in systems of interest is provided by a lamp emitting a constant intensity; in chemiluminescent systems steady excitation is provided by molecules undergoing chemical reactions.

A Long-Range Quenching and a Heavy Atom Effect. Indirect Chemiluminescence and Electronic Energy Transfer

Both 1A and 3A , as we have noted, are capable of emitting light as fluorescence and phosphorescence,

(24) H. E. O'Neal and W. R. Richardson, *J. Amer. Chem. Soc.*, **92**, 6553 (1970); correction; *ibid.*, **93**, 1828 (1971).

(25) (a) S. P. McGlynn, P. J. Smith, and G. Cilento, *Photochem. Photobiol.*, **24**, 433 (1964); (b) L. Salem and C. Rowland, *Angew. Chem.*, **11**, 92 (1972).

respectively. Certain additives, Q, can emit light after quenching 1A and 3A . *Indirect chemiluminescence* is the term for the observation of emission from *Q when 1 is thermolysed in the presence of Q. Three types of electronical energy transfer²⁶ have been studied with the use of 1 to generate 1A and 3A in the presence of strongly absorbing energy acceptors: (a) singlet-singlet (SS) transfer, $^1A + Q \rightarrow A + ^1Q$; (b) triplet-triplet (TT) transfer, $^3A + Q \rightarrow A + ^3Q$; and (c) triplet-singlet (TS) transfer, $^3A + Q \rightarrow A + ^1Q$. Processes a and b have been well studied by standard photoexcitation techniques, but not, of course, with excited acetone (because of its feeble absorption) and acceptors such as anthracenes and naphthalenes. Triplet-singlet energy transfer is a relatively rare type of energy transfer, but can occur efficiently if care is employed in selection of Q.

For the sake of simplicity, let us assume that *all* of the observed indirect chemiluminescence observed upon addition of Q is due to only one of the three transfer processes a, b, or c. The observed intensity of light is then given by eq 11, 12, or 13, respectively.

$$I^{SS} = k_i[1] \times {}^*\phi^S \times \phi_{ET}^{SS} \times \phi_F^Q \quad (11)$$

$$I^{TT} = k_i[1] \times {}^*\phi^T \times \phi_{ET}^{TT} \times \phi_F^Q \quad (12)$$

$$I^{TS} = k_i[1] \times {}^*\phi^T \times \phi_{ET}^{TS} \times \phi_F^Q \quad (13)$$

The expressions for indirect chemiluminescence (I^{ET}) consider the probability (ϕ_{ET}) that *A will transfer excitation to Q and the emission yield (ϕ_e^Q) of *Q . The key parameter in eq 11-13 is obviously ϕ_{ET} which, in general, is given by eq 14. In words,

$$\phi_{ET} = \frac{k_{ET}[Q]}{k_q[Q] + k_{*A}} \quad (14)$$

or

$$(\phi_{ET})^{-1} = (k_q/k_{ET}) + (k_{*A}/k_{ET})[Q]^{-1}$$

the efficiency of energy transfer (ET) depends on the competition between the ET path and all bimolecular quenching paths ($k_q[Q]$) and unimolecular decay paths (k_{*A}) of *A . Since $I^{ET} \propto \phi_{ET}$, from eq 14 we see that

$$(I^{ET})^{-1} \propto (k_q/k_{ET}) + (k_{*A}/k_{ET})[Q]^{-1} \quad (15)$$

so that experimentally a study of the variation of I^{ET} with $[Q]$ can lead to a determination of the ratio k_q/k_{ET} and k_{*A}/k_{ET} . From independent direct measurement of k_{*A} , both k_{ET} and k_q can be calculated.

Some interesting conclusions derive from these and other data from our laboratories: (a) SS transfer from 1A to anthracene occurs, in general, with a rate constant ($k_{ET}^{SS} \sim 6 \times 10^{10} M^{-1} \text{ sec}^{-1}$) about an *order of magnitude* larger than the rate constant (in benzene) for diffusion-limited quenching ($\sim 10^{10} M^{-1} \text{ sec}^{-1}$);²⁷ (b) exothermic TT transfer from 3A to a variety of acceptors occurs with a similar rate constant approaching ($k_{ET}^{TT} \simeq 3 \times 10^9 M^{-1} \text{ sec}^{-1}$) but invariably *lower* than that for diffusion-limited quenching; (c) exothermic TS transfer to anthra-

cenes occurs with rate constants which vary from low values for non-heavy-atom-substituted anthracenes ($k_{ET}^{TS} \simeq 10^6 M^{-1} \text{ sec}^{-1}$) to a value ($k_{ET}^{TS} \simeq 10^9 M^{-1} \text{ sec}^{-1}$) approaching that for TT transfer for 3A to 9,10-dibromoanthracene (DBA).

Each of the above results has important implications with respect to energy-transfer mechanisms. The ultrafast rate constant for the 1A to anthracene energy-transfer process demands a *long-range* mechanism for the process. Radiative transfer (emission by 1A followed by absorption by anthracene) is ruled out because many more photons are observed in the indirect than in the direct chemiluminescence; 1A must be quenched *before* it emits. It thus appears that the SS mechanism in this case is of a Forster²⁸ or resonance type. Substantiating this conclusion is the fact that the rate constant and efficiency of singlet-singlet energy transfer are comparable in both fluid solution or in a rigid polymer matrix.

Remarkably, triplet-singlet energy transfer from 3A to DBA also occurs *via* a long-range mechanism as shown by the observation that energy transfer from 3A to DBA at a given concentration is unaffected by comparable concentrations of short-range collisional quenchers, such as 1,4-dibromonaphthalene, in a polymer matrix.

The large value of the rate constant for the TS energy transfer to DBA demonstrates the ability of "heavy atoms" to relax the spin forbiddenness of an elementary chemical step.²⁹ The heavy atom effect is similar in character to that which causes the thermolysis of 1 to experience a selection rule which *favours* the spin-forbidden possibility. A simple classical picture of this effect indicates that when electrons get close to the nucleus of a bromine atom the exchange of a spin and angular momentum is very fast because the electron must accelerate as it approaches the nucleus in order to avoid being drawn in by the positive charge. The accelerated charge in turn generates a tremendous magnetic field which can interact with the electron's spin and cause it to "flip." Heavy atoms are more effective than light atoms because the electron's acceleration, as it approaches, must be much greater to avoid being drawn into a bromine nucleus ($Z = 53$) than for, say, a carbon nucleus ($Z = 6$).

In summary, indirect chemiluminescence of energy acceptors excited by 1A or 3A generated from 1 (which serves as a "masked" excited state), can lead readily to information on a variety of energy-transfer mechanisms. The relatively high singlet and triplet energy of acetone allows a wide choice of lower energy acceptors. Furthermore, the unique ability of selectively triggering formation of *A in the presence of strongly absorbing acceptors opens areas of study which are only difficultly accessible *via* standard photoexcitation techniques.

Quantum Chain Reactions. Autocatalytic Decomposition of Tetramethyl-1,2-dioxetane

The observation of photosensitized generation of *A from 1 and the effectiveness of energy-transfer processes discussed above open some remarkable av-

(26) Review of electronic energy transfer processes: A. A. Lamola and N. J. Turro, "Energy and Organic Photochemistry," Wiley, New York, N. Y., 1969.

(27) (a) This value is the largest reported, to our knowledge, in the literature for a diffusional process in acetonitrile. See, for example, W. R. Ware and J. S. vros, *J. Phys. Chem.*, 70, 3246 (1966). (b) For a discussion of diffusional quenching by triplet-triplet energy transfer, see: P. J. Wagner and I. Kochevar, *J. Amer. Chem. Soc.*, 92, 2338 (1968).

(28) T. Forster, *Discuss. Faraday Soc.*, 27, 7 (1959).

(29) D. S. McClure, *J. Chem. Phys.*, 17, 905 (1949); M. Kasha, *ibid.*, 20, 71 (1952).

enes of research. Imagine that *A produced from 1 transfers its energy to Q to yield *Q. If this *Q is capable of interacting with 1 to trigger generation of more *A, we have the essence of a *quantum chain sequence*,³⁰ i.e., a chain sequence in which an electronically excited state is produced by an electronically excited precursor (eq 16 and 17).

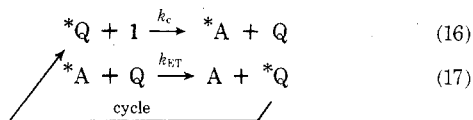

The recurrence and length of the chain sequence will depend on τ_Q , the lifetime of *Q, τ_A , the lifetime of *A, the concentrations of 1 and Q, and the rate constants k_c and k_{ET} .

Let us consider some specific cases of this chain sequence: first, the special case in which $Q = A$, then $k_c = k_{ET}$, and $\tau_Q = \tau_A$. This process is the *autocatalytic decomposition* of 1 by its product *A (eq 18). In this case, the only important factors in deter-

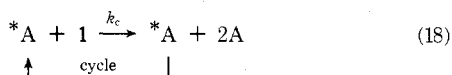

mining the chain participation are τ_A , [1], and k_c . Indeed, it is easy to show that the *chain length* of the sequence is simply the probability that *A will pass through a cycle relative to all means of decay. We have found experimentally that the chain reaction involving triplet acetone has an efficiency of producing ³A of nearly 100%. Thus the chain length can easily be shown to be given by $k_c[1]/k_A = k_c\tau_A[1]$, i.e., the rate of the chain process relative to unimolecular decay of ³A. In fact, in CH₃CN the value of k_c is found to be about $10^9 M^{-1} sec^{-1}$ and τ_A is about $10 \times 10^{-6} sec$, so that at $10^{-1} M$ 1, the chain length³¹ is about 1000!

Quantum Chain Reactions. Application to the Study of Molecular Diffusion of Molecules in Solution, Cage Effects, and Excited-State Lifetimes

A crucial primary event in solution chemistry is the diffusion of reactive species into a solvent cage, i.e., the occurrence of solution "encounters" of molecules involved in bimolecular processes.³² Thus, both molecular diffusion (e.g., its rate and specific mechanism) and cage effects (e.g., the details of interactions between reactive species in the solvent cage) are of fundamental importance for an understanding of the rates of reactions which reflect the rate of diffusion of reactants in a solvent rather than the inherent reactivity of the reactants in an encounter complex.

Operationally, how does one determine whether a reaction is limited by molecular diffusion? A survey of the literature reveals that two criteria are commonly employed.³³ The first criterion is based on a

theoretical model for diffusion of small molecules which predicts that $k_{DIF} (M^{-1} sec^{-1}) = 2.2 \times 10^5 T/\eta$. At 300 K, for typical fluid organic solvents ($\eta \approx 10^{-2} P$) the calculated $k_{DIF} \approx 10^9-10^{10} M^{-1} sec^{-1}$. The second criterion is based on measured rates and assumes that a reaction is diffusion limited when the measured rates approach a limiting value $10^9-10^{10} M^{-1} sec^{-1}$ and become independent of structure of the reagents. Thus, a diffusion-controlled reaction is one for which the reaction rate is governed by the rate with which two reagents diffuse together into the solvent cage, rather than by the probability of reaction within the solvent cage or encounter complex.³²

The details of steps 16 and 17 suggest an interesting application of the quantum chain sequence for study of molecular diffusion in solution. From the results of previous studies²⁶ on energy transfer in solution, we can accurately anticipate the conditions under which steps 16 and 17 will be a collisional process, i.e., require a collision encounter between *Q and 1 (eq 19) and *A and Q (eq 20)

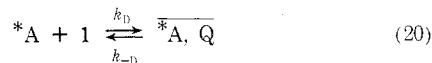
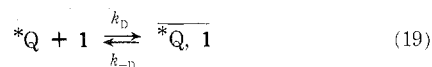

If exothermic energy transfer is diffusion controlled, eq 20 is *irreversible* because transfer to form *Q must occur with unit efficiency in the solvent cage. Evidence is available which suggests that exothermic collisional singlet-singlet transfer is, in fact, diffusion controlled. We are able to provide evidence that this is not the case for exothermic triplet-triplet transfer by employing the chain sequence.

The key idea is the notion that, as a result of step 19, electronically excited 1 is formed in the *same solvent cage with Q* (eq 21), and that fragmentation of excited 1 into *A takes place in the *same solvent cage with Q* (eq 22).

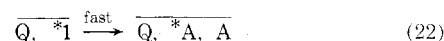

If energy transfer is diffusion controlled, step 23 to quench *A will occur with unit efficiency. However, if *A escapes the cage (eq 24), then experimentally

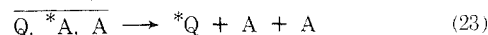

the "quench" of *A which produced *Q (eq 17) has been *nullified* since *A has been resurrected in step 24! The latter situation appears to obtain for exothermic triplet-triplet transfer, thereby leading to the conclusion that exothermic triplet-triplet energy transfer is not diffusion limited. This same conclusion was previously derived from a different method of analysis (*vide supra*). An intriguing aspect of the chain sequence is that it occurs efficiently, so that the measured decay of [³A] does not change at the steady state even though many ³A molecules are being quenched by step 17 (they turn out to be regenerated just as fast in step 16!).

Space limitations prevent discussion of the kinetics of the quantum chain sequence. Suffice it to

(30) P. Lechtken, A. Yekta, and N. J. Turro, *J. Amer. Chem. Soc.*, **95**, 3027 (1973).

(31) The chain length is defined, in this case, as $k\tau_A[1]$, and can be seen to depend on the rate constant for the chain-carrying step, the decay of acetone triplet, and the concentration of 1.

(32) R. M. Noyes, *Progr. Reaction. Kinet.*, **1**, 131 (1961).

(33) There is an inherent dilemma in deciding whether a process is diffusion controlled, since the "fastest rate constant" observed may be due to a long-range process rather than a diffusional, encounter-limited process.

point out that the chain length and efficiency depend on τ_Q , since the longer the lifetime, the higher the probability that *Q will encounter 1 and continue chain propagation.

Quantum Chain Reactions. Anti-Stokes Photosensitization. A "Red-Light" to "Blue-Light" Transformation

The quantum chain sequence involving 1 can be initiated either by thermolysis or photolysis of 1 or by photosensitization (e.g., Q absorbs a photon and *Q (rather than *A) initiates the chain). Many triplet photosensitizers appear to be capable of effecting reaction 25. Interestingly, if $E_3(Q) < 78$ kcal/mol

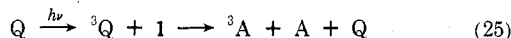

(the energy of 3A), eq 25 represents an anti-Stokes photosensitization since more energy is available from 3A than from the absorbed photon (assuming for the sake of argument direct excitation to 3Q).

What is the lowest energy of 3Q which could effect eq 25 efficiently? As long as $E_3(Q)$ plus the reaction enthalpy and activation enthalpy are greater than $E_3(A)$, eq 25 is *exothermic*, i.e., can proceed, in principle, with negligible activation energy. Since the reaction enthalpy plus available thermal energy at room temperature is ≈ 70 kcal/mol for eq 25, we conclude that $E_3(Q)$ can be as low as 10 kcal/mol and still efficiently effect reaction 25! This is a remarkable possibility since 10 kcal/mol corresponds to light of wavelength equal to 2600 nm (3850 cm^{-1}), i.e., infrared light! Since 3A emission occurs in the 400–450-nm region, this (so far) hypothetical process would correspond to an anti-Stokes photosensitization in which infrared light is transformed into blue light!

A rather convincing experimental verification³⁴ of the notion of an anti-Stokes photosensitization is demonstrated by the biacetyl ($E_3 = 56$ kcal/mol) photosensitized decomposition of valerophenone ($E_3 = 74$ kcal/mol) in the presence of 1.

Figure 3 will serve to guide our thinking on the microscopic interpretation of this unusual observation. Experimentally, one can selectively photoexcite biacetyl in the presence of a large excess of valerophenone. No sensitized decomposition of valerophenone is observed under these conditions, however, because energy transfer from biacetyl (B) to valerophenone (V) is endothermic by nearly 20 kcal/mol, too large an amount of thermal energy to be picked up by B or V during the lifetime of 3B . With 1 as a relay, however, photosensitization of valerophenone photochemistry is readily and efficiently achieved. Demonstration of this effect was possible by using the type II reaction of valerophenone as a probe for electronically excited molecules. This reaction proceeds exclusively via the valerophenone triplet, which possesses an energy content of about 74 kcal/mol in excess of its ground state. These results mean that an excited state of biacetyl has sensitized formation of excited acetone, which in turn transfers its excitation to valerophenone which rapidly cleaves in a type II process (Figure 3).

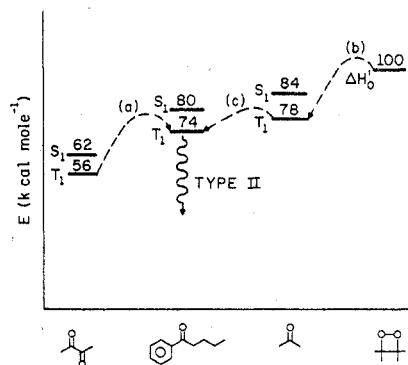

Figure 3. Energy diagram of the "anti-Stokes" sensitization of the type II reaction of valerophenone by biacetyl, with 1 as a relay. Direct excitation of T_1 of valerophenone by biacetyl triplets (path a) is energetically unfavorable and not observed. The T_1 state of biacetyl, however, is able to generate acetone triplets from 1 (path b). These acetone triplets, in turn, sensitize the formation of valerophenone triplets, which then undergo type II reaction (path c).

In summary, we have demonstrated a principle which apparently has not been utilized heretofore, namely, the efficient use of a molecule of high energy content as an excited-state equivalent in a sensitization relay which eventuates in an electronically excited state whose energy is well to the "blue" of an initially absorbed photon. In effect, we are dealing with a "two-quantum" process in which one of the quanta is *masked* in the chemical energy of the dioxetane. Since acetone is an effective sensitizer in many photochemical and photobiological systems, it should be of special interest to organic chemists and to biochemists to generate excited acetone molecules employing long-wavelength excitation and very mild conditions.

Molecular Diffusion vs. Electronic Excitation Diffusion. Direct Chemical Demonstration of a Null Reaction

Imagine exciting a solution of acetone with light. The electronically excited acetone molecules, *A , which happen to be produced by absorption of the light find themselves immersed in a sea of ground-state acetone molecules. Now suppose a quencher molecule exists at some distance, R , from the site of an *A molecule. The excitation of *A may be quenched by one of two pathways: (a) material or molecular diffusion of *A through solvent A molecules until encounter with Q or (b) excitation diffusion by excitation hopping from *A to an adjacent A molecule, and continuation of the excitation hopping until an *A and Q are encounter partners. Schematically (Figure 4) the competition between paths a and b is competition between a "random molecular walk" of *A to the site of Q and an "electronic excitation relay" with solvent A molecules serving as the relay team.

These ideas are part of a more general set of "null" or degenerate photochemical processes (eq 26), which has some special theoretical and practical implications.³⁵

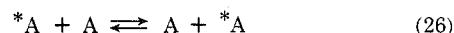

(34) N. J. Turro and P. Lechtken, *Tetrahedron Lett.*, 565 (1973); N. J. Turro, N. E. Schore, H. C. Steinmetzer, and A. Yekta, *J. Amer. Chem. Soc.* 96, 1936 (1974).

(35) P. Lechtken and N. J. Turro, *Angew. Chem., Int. Ed. Engl.*, 12, 314 (1973).

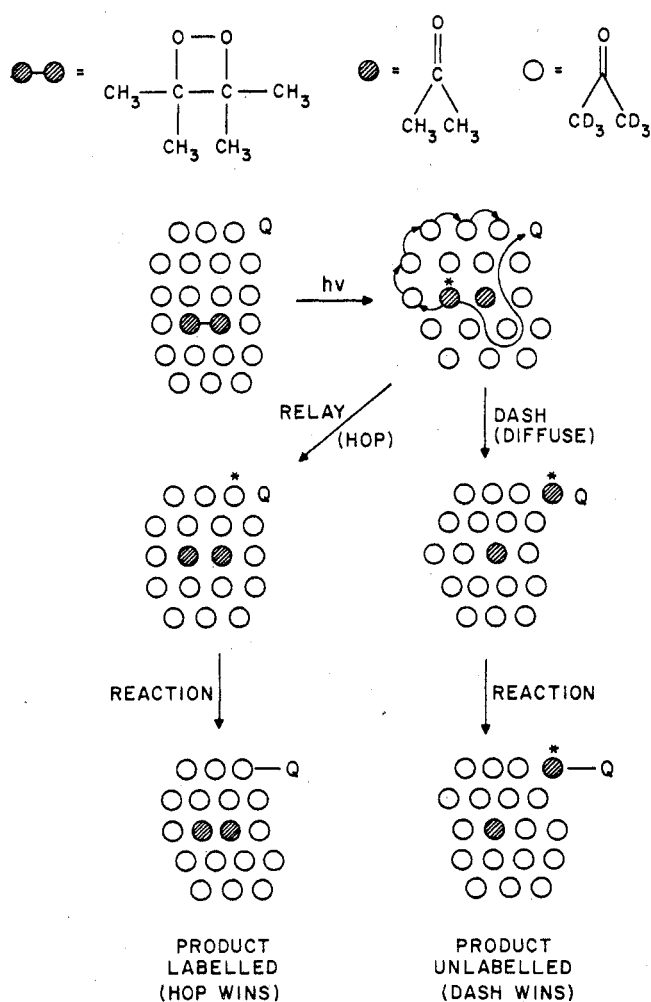

Figure 4. Possibilities for energy transfer in liquid acetone. An originally excited acetone molecule (unlabeled, shaded circles) is generated in labeled acetone solvent (open circles). The excited unlabeled acetone can diffuse to the site of Q and react with it (to produce an unlabeled acetone-Q adduct). The excited unlabeled acetone can also transfer its excitation to a labeled acetone molecule in the solvent. The transfer act is irreversible because of the much higher concentration of unlabeled acetone. The excited unlabeled acetone may then react with Q to produce a labeled acetone-Q adduct. Thus, the occurrence of two fundamentally different mechanisms of a relay (hop) of energy through the solvent or material diffusion (dash) of energy through the solvent may be evaluated by analyzing for the occurrence or absence of label in the acetone-Q adduct.

A convincing demonstration of the occurrence of reaction 26 is an intriguing experimental challenge. As a first step toward meeting it, consider the notion of labeled acetone (A- d_6) solvent that contains a number of isotropically distributed, but electronically excited, unlabeled acetone molecules (*A- h_6). Now consider as a specific quencher an ethylene capable of forming an oxetane with *A. If we could achieve the initial conditions described above (*A- h_6 in A- d_6 at $t = 0$), we could test for excitation diffusion by simply analyzing for oxetane containing the elements of A- d_6 . Figure 5 outlines the key processes where k_{hop} is the rate constant for energy hopping via excitation hopping, and k_{ox}^{H} and k_{ox}^{D} are the rate constants for formation of oxetanes for *A- h_6 and *A- d_6 , respectively.

The problem boils down to the specific generation of *A- h_6 in solvent A- d_6 . This is, as the reader may have guessed by now, an easy task for our hero, 1. The selective $\Delta H \rightarrow *$ can be used to uniquely gener-

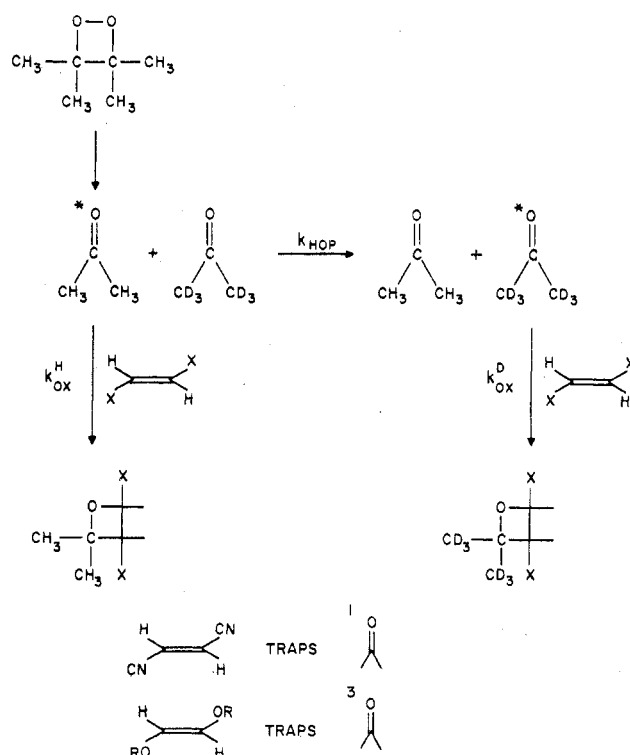

Figure 5. Flow diagram of the titration of unlabeled and labeled electronically excited acetone molecules. 1,2-Dicyanoethylene reacts specifically with singlet acetone and 1,2-diethoxyethylene reacts specifically with triplet acetone. The occurrence or nonoccurrence of deuterium in the oxetane product allows calculation of the extent of energy hopping from initially excited unlabeled acetone (produced from 1) to the labeled acetone solvent.

ate *A- h_6 from 1 in A- d_6 solvent! Furthermore, since we know from earlier studies³⁶ that 1,2-dicyanoethylene (DCE) reacts efficiently only with ^1A and that 1,2-diethoxyethylene (DEE) reacts efficiently only with ^3A , we can measure both singlet excitation hopping and triplet excitation hopping. Experimentally, it is found that at 0.1 M DCE 5% of the oxetane from ^1A contains d_6 and at 0.1 M DEE 10% of the oxetane from ^3A contains d_6 . Since k_{ox}^{H} , which must be essentially identical to k_{ox}^{D} , is known for both $^1\text{A} + \text{DCE}$ and for $^3\text{A} + \text{DEE}$, we can easily calculate $k_{\text{hop}}^{\text{S}}$ and $k_{\text{hop}}^{\text{T}}$ for singlet hopping and for triplet hopping, respectively.

The results of the evaluation of $k_{\text{hop}}^{\text{S}}$ and $k_{\text{hop}}^{\text{T}}$ are that, within the experimental error, both are equal to $\approx 3 \times 10^6 \text{ M}^{-1} \text{ sec}^{-1}$. The rate constant for energy diffusion through acetone solvent is 3-4 orders of magnitude smaller than that for molecular diffusion ($k_{\text{dif}} \approx 10^{10} \text{ M}^{-1} \text{ sec}^{-1}$ in acetone)³⁷ through the solvent. In terms of the "random walker," excited acetone would easily beat the "relay team" of acetone molecules in the microscopic race to Q!

Another conclusion from these data is that ^1A makes less than one hop during the average time required for deactivation of singlet acetone and that ^3A makes about 1000 hops during the average time required to deactivate an acetone triplet (number of hops = rate of hopping \times lifetime). It is important to note that energy hopping does not prolong the

(36) N. J. Turro, *Pure Appl. Chem.*, 27, 697 (1972).

(37) The viscosity of acetone is comparable to that of acetonitrile, so that we can expect k_{dif} to be nearly the same for both solvents.

lifetime of an excited acetone molecule, but it does allow excitation to "visit" a larger number of acetone molecules, especially in the triplet.

Measurement of Activation Parameters of Exceedingly Slow Reactions. Demonstration of Identity of Activation Requirements for Generation of Acetone Singlet and Triplets

The chemiluminescence of 1 can be easily observed under conditions in which the substance is "thermally stable." Thus, we have a seeming paradox. Chemiluminescence requires decomposition of 1, yet 1 chemiluminesces under conditions such that it is kinetically stable! The paradox is solved by considering the extremely high sensitivity of the chemiluminescence measurement.³⁸ At low temperatures the number of molecules which need decompose, in order to produce sufficient light for a measurement, is so small that we are hard pressed to detect reaction from 1 *except by the chemiluminescence technique*. Indeed, indirect chemiluminescence from 1 can be observed even at -10° , a temperature at which the half-life of 1 is calculated to be over 100 years!

The activation energy for chemiluminescence from

$$\Delta E_{CL}^F = \Delta E_D + {}^* \Delta E^S + \Delta E_F \quad (27)$$

$$\Delta E_{CL}^P = \Delta E_D + {}^* \Delta E^T + \Delta E_P \quad (28)$$

1 is given by eq 27 and 28, for fluorescence (ΔE_{CL}^F) and phosphorescence (ΔE_{CL}^P), respectively. In other words, before a chemiluminescent photon can be measured, its production goes through three activated stages: (a) that for formation of the transition state for decomposition of 1 with associated activation energy ΔE_D ; (b) that for formation of excited singlet (or triplet) acetone with, associated activation energy ${}^* \Delta E^S$ (or ${}^* \Delta E^T$); and (c) that for emission of fluorescence (or phosphorescence) with associated activation energy ΔE_F (or ΔE_P).

Consider Figure 6 which shows the energetic position of the transition state (TS) for decomposition of 1 relative to acetone (A), excited singlet acetone (1A), and triplet acetone (3A). Three choices exist: (a) TS is higher in energy than both 1A and 3A ; (b) TS is intermediate, being lower in energy than 1A and higher in energy than 3A ; (c) TS is lower in energy than both 1A and 3A . Choice three is ruled out on the basis of the very high (nearly quantitative) yield of 3A , but is further substantiated by the observation that, when ${}^* \Delta E^T$ is measured by application of eq 27 (*i.e.*, ΔE_{CL}^P , ΔE_D , and ΔE_P are independently measured), a value of zero is obtained. Perhaps more significantly, ${}^* \Delta E^S$ is also found to be equal to zero, thereby eliminating choice b in Figure 6. This conclusion, in turn, is consistent with the energetics shown in Figure 1, *i.e.*, $\Delta H_0 + \Delta H > E({}^1A)$ or $E({}^3A)$.

Conclusion and Future Studies

Two simple ideas, namely, use of 1 as a specific storehouse of excited acetone molecules and use of one simple measurement, I_{CL} , by sensitive chemilu-

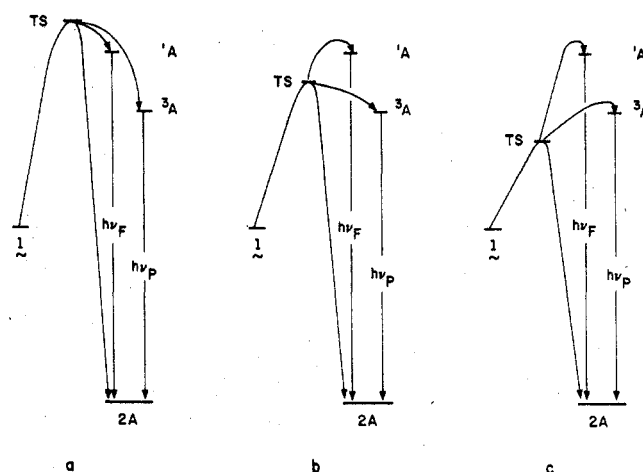

Figure 6. Model a: position of TS is above that of 1A and 3A . Model b: position of TS is between 1A and 3A . Model c: position of TS is below 1A and 3A .

minescence techniques, have allowed us to scan a number of established chemical phenomena and have suggested experiments which lead to the discovery of new and exciting kinds of chemistry.

Future studies should be directed at structure-reactivity relationships for other dioxetanes. New developments can exploit the findings discussed above. For example, one can imagine the use of bright chemiluminescence from dioxetanes in fluctuation spectroscopy, a technique which requires high sensitivity in order to study the motions of molecules in a volume so small that some property of the number of molecules within and without the volume can be measured as a function of time. Chemiluminescence by this technique may yield basic information about diffusional processes and reaction dynamics.

One can also imagine the use of dioxetane systems as "chemical pumps" for lasers which will emit visible light. Perhaps infrared photons will be able to trigger the $\Delta H \rightarrow {}^*$ of dioxetanes; a new field of "infrared photochemistry" might be at hand. Since chemiluminescence is observed from crystals of 1, we can anticipate studying the properties of the solid state by chemiluminescence techniques.

Finally, a rather high steady-state concentration of excited states is possible and could be exploited as a sort of "steady-state" flash photolysis technique, which might have uses in studies involving electron spin resonance, and might lead to unusual nmr phenomena. Even the standard physical and spectral properties of dioxetanes are likely to be interesting *per se*. For example, is the mass spectrum of 1 similar to acetone (a molecular ion of 1 is, in fact, observed!), or does the fragmentation of 1 show peculiar behavior because of its high energy content?

Tetramethyl-1,2-dioxetane is a remarkably versatile and useful molecule. During the last 2 years it has been a source of great delight to us because it offers an experimentally simple means to test some relatively complicated ideas and to measure otherwise difficultly measurable quantities. The interplay of concepts and techniques of different disciplines has been found to be most beneficial in the evolution of this research. We hope and believe that the fun has really just begun.

(38) H. C. Steinmetzer, A. Yekta, and N. J. Turro, *J. Amer. Chem. Soc.*, 96, 282 (1974).